

JEWETT[®] C20 Fitting Instructions

1. With the patient lying on their back, loosen the four adjustment screws on the horizontal bars and the four adjustment screws on the vertical bars and place the brace on the chest of the patient.
2. Slide the vertical and horizontal bars into proper position.
 - A. The pectoral pads should be parallel to and 1/2" below the clavicles.
 - B. The bottom of the pubic pad should be 2" above the pubis.
 - C. The side pads should not be in contact with the body.
3. Tighten the 8 adjustment screws.
4. The side pads can be bent slightly in or out as needed for comfort.
5. Pull the strap through the innermost slot of the right side pad and through the chafe loop. Secure the strap by pressing the hook and loop together.
6. Adjust the opposite side of the strap to the proper length by pulling and readjusting the strap in the side pad slots.
7. To adjust the pectoral pads (A) for comfort, loosen the pad retainer screws (B) and rotate to the desired position. To narrow the width between the pads remove the outside screw (C) and rotate the pad. Use the inner threaded hole (D) to reinsert the screw. **DO NOT** twist or use excessive force on the pads while in place to prevent breakage of the silicone posts.
8. The brace is set for a right hand closure and will work fine for most patients. Instructions for changing to a left hand closure are shown on the back of this page.

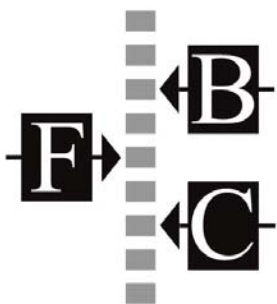

J GENUINE
JEWETT[®]
There is no substitute.



**Florida
Brace
Corporation**

601 W. Webster Avenue
Winter Park, Florida 32789
800-327-0870
Fax: 407-644-4698
www.flabrace.com

Instructions for Reversing the JEWETT® C20 Strap Assembly For a Left-Hand Closure

1. Remove the lumbar pad (B) and strap (D) from brace. (Figure 1)
2. Place brace on a table with inside facing you and the pectoral pads (A) at top. (Figure 1)
3. Hold strap with hook and loop closure of the strap (D) facing you. Pull the lumbar pad (B) off of the strap. (Figure 1)

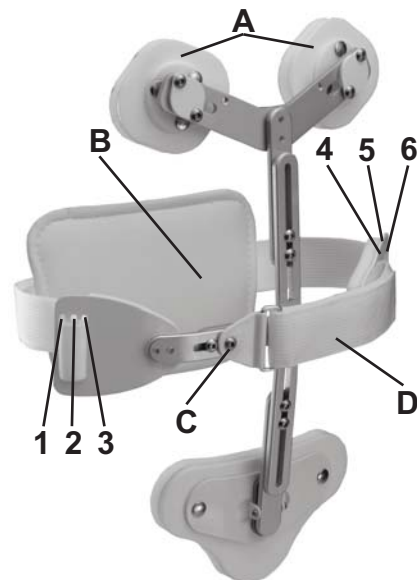

Figure 1

4. Reinsert the strap (D) into the opposite end of the pad (B) with the belt loops still facing you. This ensures the narrower portion of the pad is still inferior on the patient's back. (Figure 2)
5. With the open hook and loop closure of the strap (D) still facing you insert the plain end of the strap down through the innermost slot of left plate (4). (Figure 2)



Figure 2

6. Next, insert the strap down through the outermost slot (6) while keeping the loops loose with plenty of slack. (Figure 3)
7. Then insert the strap down through the middle slot (5) while maintaining slack. (Figure 4)
8. Now insert the strap back up through the innermost slot (4). (Figure 5)



Figure 3

9. Tighten the loops by pulling on the end of the strap.



Figure 4



Figure 5

10. Remove the screw holding the chafe (C) to the front of the brace and move the chafe to the opposite side of the brace. Be sure the metal loop faces the center of the brace.

11. Insert the hook and loop end of the strap (D) through the innermost of the three slots (3) on the right side plate. If desired, for larger patients the strap can be placed in slots 1 or 2. (Figure 6)

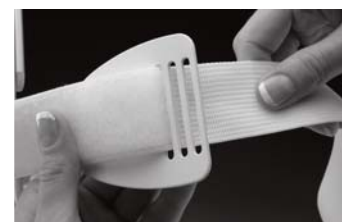

Figure 6